

## Top Mounted Aluminum Block & Cover System

### DTA93-GLS

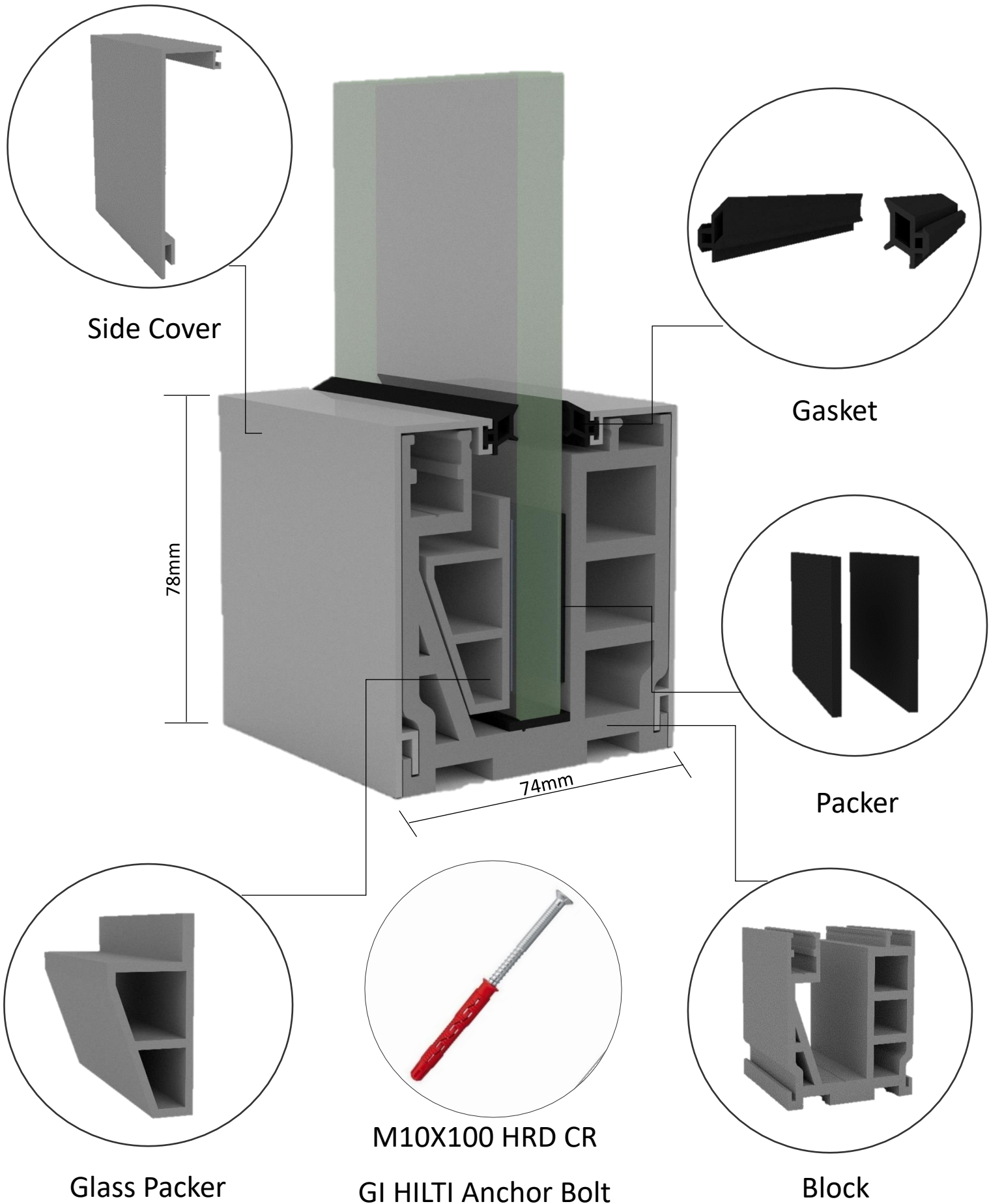

## Specification

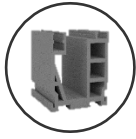

### **Block:**

- Material: AL6063 T6
- Length: 75mm
- Height: 78mm
- Width: 74mm
- Approx Weight: 0.420 KG / Nos



### **Covers :**

- Material : AL6063 T6
- Length : 12 Feet / 16 Feet
- Weight : 2.87 KG / 16 Feet

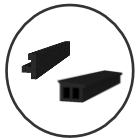

### **Gasket:**

- Micro Cured & EPDM Rubber



### **Wedges:**

- Material: AL6063 T6



### **Anchor Fastner:**

- Type: Hilti HRD C M10X100/120/140/160 (Counter Sunk) (As per client's requirement)



### **Powder Coating:**

- Type: AkzoNobel
- Color/Shade: As per client preference and subject to availability and feasibility
- Coat thickness: 80-100 Microns
- Coating warranty: 10 years of warranty

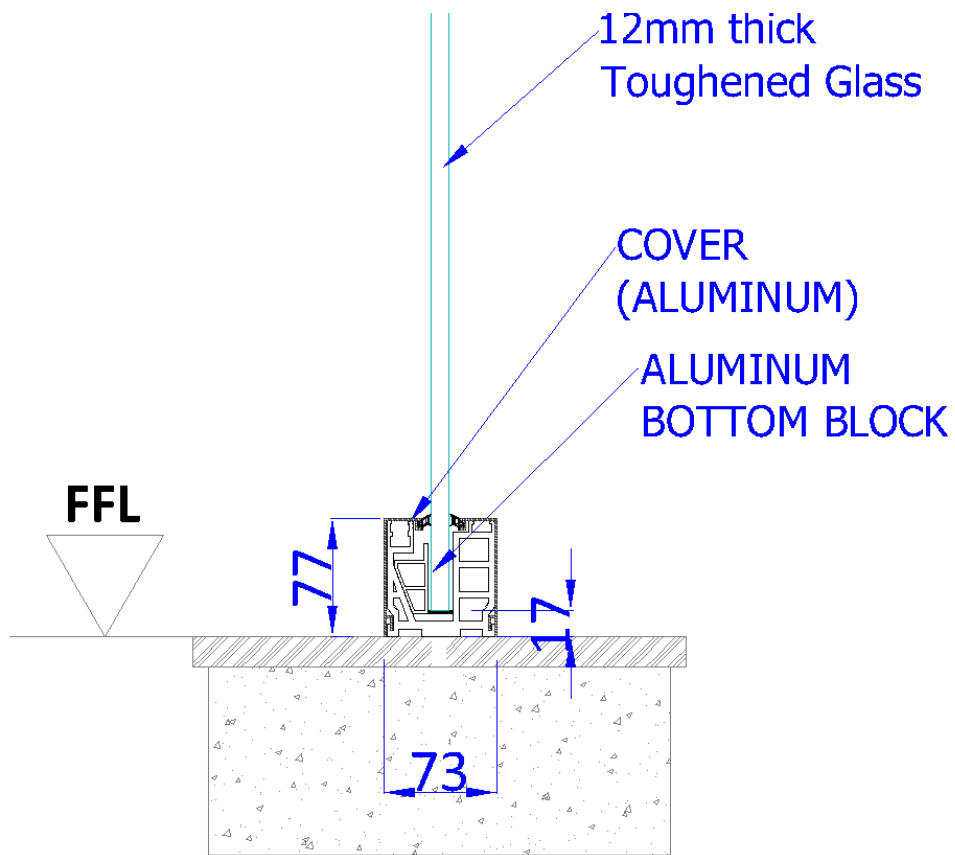

**SIDE VIEW**